

## Challenge

Installing a full-blown station as a part of a Road Weather Information System (RWIS) requires many sensors and other technical components, which can be cost prohibitive. As a result, many places are left unmonitored.

## Solution

Using a combination of two, all-in-one sensors from OTT HydroMet can get a large array of data at a fraction of the cost. The compact weather station Lufft WS600 and the optical road weather sensor Lufft NIRS make a perfect pair.

## Benefits

Less maintenance, labor, and costs required while still providing the data that they need allows the end customers to maintain their roads. This frees up personnel to tend to other areas where sensor technology may not be prevalent.

## Project: RWIS Lite

When budgets are tight but accurate and reliable data is still important for specific locations, a slim “RWIS Lite” may be a smart solution. Combining a compact weather sensor as the Lufft WS600, that measures all atmospheric parameters with an optical road condition sensor Lufft NIRS31 provides reliable data for a variety of road weather parameters.

Not only does this keep the costs of hardware low but it minimizes the installation requirements, resulting in less time spent in the field, less cables, brackets, mounts, and points of failure.

This setup is especially useful to fill data gaps at locations that are not part of an extended RWIS network. Our customer achieved the desired result of monitoring all required parameters, at a fraction of the cost that comes with a standard RWIS.



Slim yet powerful RWIS setup with a NIRS31 road sensor, a WS600 weather station, and a camera. *Credit: OTT HydroMet*

## Product List

Lufft NIRS31, Lufft WS600, Lufft Communicator LCOM, optional camera

## Schematic Setup

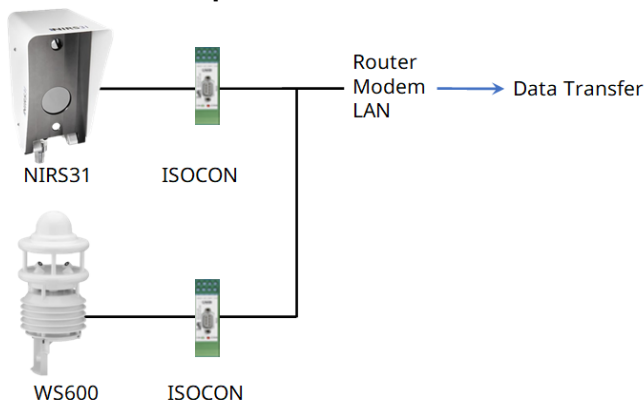

## Further information

Turn on weather warnings right on time with LCOM

## Contact

Questions? Let's talk!



## Challenge

The top parking deck of open parking garages is always exposed to the weather and its impact on safety.

This poses significant risks for vehicles and pedestrians, especially in winter conditions.

## Solution

The MARWIS road sensor records the road condition, temperature, and friction. The compact weather sensor WS captures various weather data. The Lufft ISOCON is a versatile interface converter to complement the system.

## Benefits

The coordinated system provides hyper-local information that enables responsible parties to immediately take necessary actions to maintain road safety, such as treating or temporarily closing the roadway.

## Project

To guarantee safe traffic on a ramp, the Swiss company Migros integrated a heating system in the roadway leading to the parking deck on the roof of its distribution center in Zurich. Thanks to a smart monitoring station from OTT HydroMet, this only comes on when needed, allowing Migros to save over 80% energy output.

**Setup:** The mobile and static Lufft MARWIS road weather sensor monitors the roadway, while the compact Lufft WS600 weather station collects relevant weather data.

The data is retrieved via modem, gateway or protocol converter. This data is then available to the heating control system in order to carry out the corresponding switching operations.

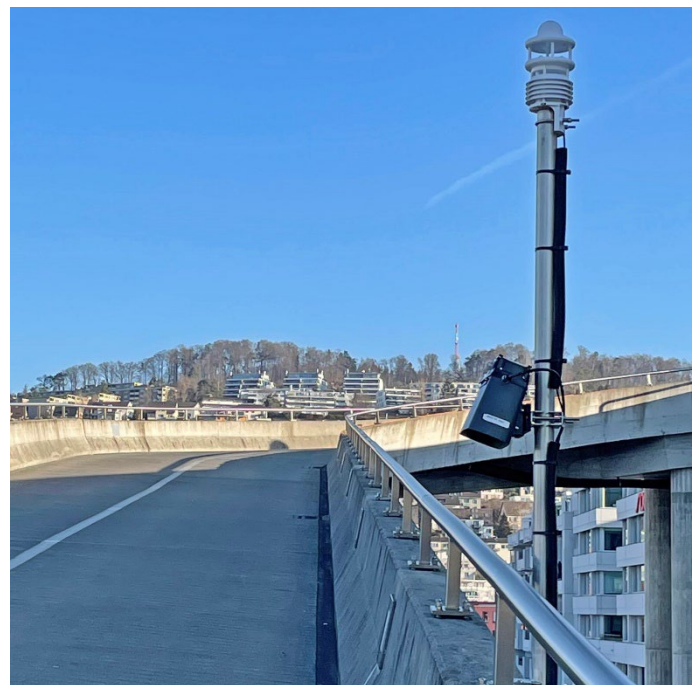

Lufft MARWIS and a weather sensor WS600 on a heated ramp leading to a parking deck. *Credit: Migros Zurich*

## System Components

MARWIS, ISOCON, Power Supply 24V, Control cabinet for installation in the parking garage, connection to network (LAN, Router, Modem)

## Schematic Setup

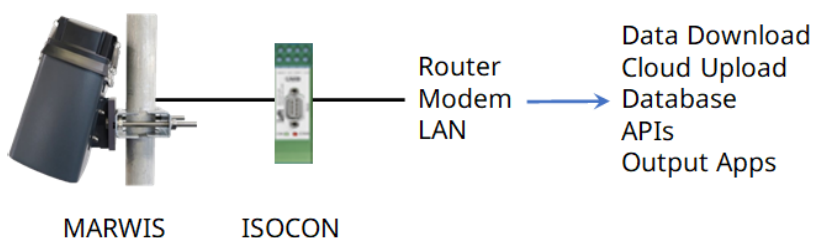

**Lufft**  
— an OTT HydroMet brand —

## Further information

[Blog: Migros Zurich fights slickness on slopes](#)

## Contact

[Questions? Reach out to us!](#)